

La Piccola



Made in Italy



Natural Refrigerant



Air cooling



speed adjustable with inverter



7,0" Touch Screen



IoT System

DESCRIPTION

COUNTER TOP, SINGLE FLAVOR MACHINE

Versions

- Available version : gravity (G).
- Air cooling.

Advantages and pluses

- Small dimensions, ideal for a wide variety of businesses.
- Tank capacity: 1x5 liters
- Production performances up to 8-10 kg/h.
- Inverter-adjustable barrel beater speed for production program and recipes.
- Environment-friendly gas and high-efficiency refrigeration circuit for a consistent energy saving.
- 7" touch screen with smart proprietary graphic interface.
- Front led light for machine status indication.
- Warning for low product level in the tank with automatic stop of the dispensing upon reaching the min. level.
- Recipe menu which allows the operator to devote to each product an ideal regulation of production and preservation.
- Possibility to set the servings count.
- CTS system (patented): a real electronic assistant which prevents malfunctions, intervening in case of possible misuse by the operator.
- Automatic restoration of active function when power supply is restored after power outage / blackout.
- Panels and closing elements developed to allow maximum accessibility to internal components for maintenance.
- Safety ON-OFF switch which disconnects electrical power loads.
- Internal overflow duct with drain in front drip-tray for easy emptying and cleaning.
- Possibility to set alarms and/or blocking alarms, guiding the operator through the compliance with all procedures ensuring the maximum machine and product hygiene.
- Event and alarm chronology menu, variables management.
- IoT System with cloud system.

DIMENSIONAL DRAWINGS

 = AIR FLOW (AIR MODELS). Note: position of air flow, position/number/dimensions of air vents refer to the air models.

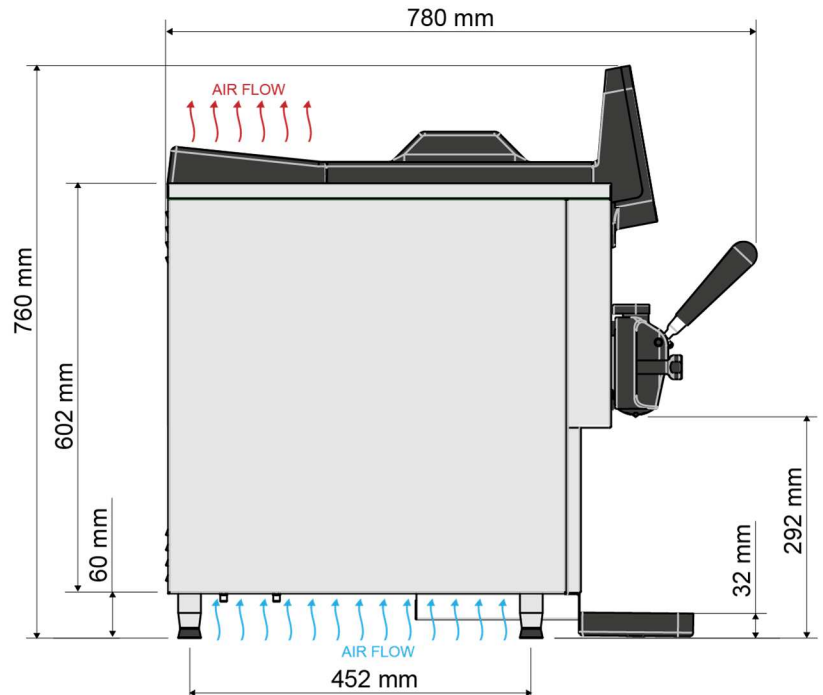
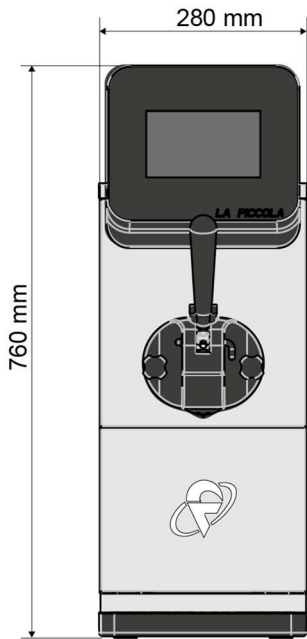

width : 280 mm



depth : 500-780 mm



height* : 760 mm



crated volume : 0,41 m³

* mounted on feet h=60 mm

TECHNICAL SPECIFICATIONS

model	pump	tank agitator	production kg/h	tank n. x lt.	cooling **	50 Hz			60 Hz			net weight kg	box weight kg
						Supply V / Hz / Ph	Power kW	Current A	Supply V / Hz / Ph	Power kW	Current A		
La Piccola	-	-	10	1 x 5	A	230/50/1	1,3	10	-	-	-	55	72

** W = Water / A = Air

Electrical

One dedicated electrical connection is required. See the Electrical chart for the proper electrical requirements. Consult your local Frigomat distributor for specifications as local codes allow.

Air Cooled

Minimum air clearances must be met to ensure adequate air flow for optimum performance.

Respect the air flow indicated in the dimensional drawings.

Beater Motor

1x370 W (0,5 hp)

Sound Pressure

< 70 dB (A)

Refrigeration System

1x642 W (1x2.190 BTU/h) @ - 23,3°C - 1x0,098 kg R290

Fan Motor

1x32 W (2 speed)

The declared production capacities are only indicative and may vary depending upon the conditions of operation and the products used.

For exact electrical information, always refer to the data label of the unit.

Specification subject to change without notice.

Frigomat S.r.l. socio unico

Via 1°Maggio, 28 - 26862 Guardamiglio (LO), ITALY

+39 0377 415011

frigomat@frigomat.com

www.frigomat.com

